

Users Manual

DIT-5200

Non-Contact Displacement Measuring System

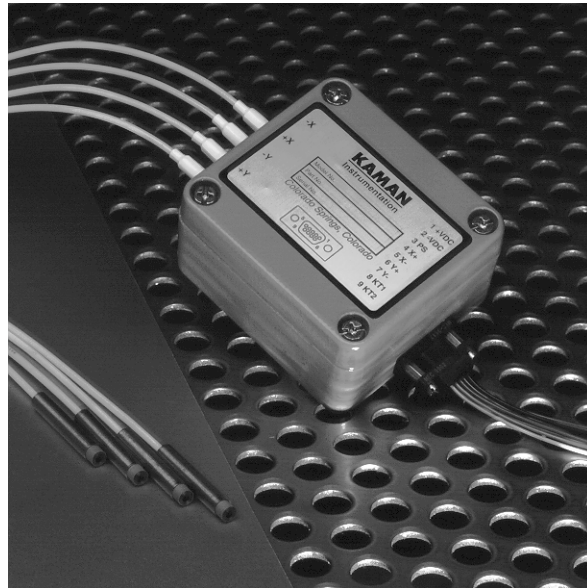

**DO NOT MAKE ANY MODIFICATIONS TO CABLE LENGTH, SENSOR OR
CALIBRATED TARGET MATERIALS WITHOUT PRIOR CONSULTATION WITH A
KAMAN APPLICATION ENGINEER**

Users Manual

DIT-5200

Non-Contact Displacement Measuring System

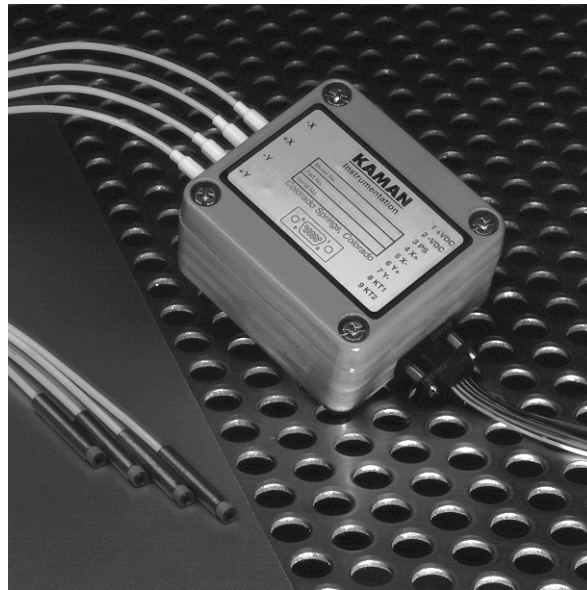

Kaman Instrumentation Operations
3450 North Nevada Avenue
Colorado Springs, CO 80907

Part No: 860134 Rev E

Table of Contents

Introduction	3
Features and Benefits	3
DIT-5200 Electronics Configurations	4
DIT-5200 Enclosure	4
DIT-5200 OEM	4
Setting up the DIT-5200.....	5
What's Included	5
Cautions and Safeguards	5
Pin out and Connector Assignments	6
I/O Connections.....	6
Sensor Connections	7
Applications Information	8
Fixturing.....	9
Sensor Mounting and Installation	10
Optimizing Performance	11
Targets (Material, Thickness, Size).....	12
Calibration.....	14
Technology.....	15
System Performance and Specifications	16
General Specifications and Typical Performance	16
Troubleshooting	19
DIT-5200 Enclosure Outline Drawing and Dimensions	20
DIT-5200 OEM Outline Drawing and Dimensions	21
DIT-5200 Sensor Dimensions	22
Terminology	23
Warranty 7A.....	24
Customer Service Information	25

Introduction

The DIT-5200 Non-contact Displacement measuring systems are a significant advance in precision measurement technology. They provide exceptional resolution, repeatability, and nulling accuracy for detecting the aligned / centered position of a conductive target relative to a pair of non-contacting sensors.

Features and Benefits

- Superior resolution
- Excellent Non-Linearity
- Enhanced thermal and long term stability
- High sensitivity
- Lower power consumption
- Small package size
- OEM packaging options
- Cryogenic sensors options

DIT-5200 Electronics Configurations

The DIT-5200 comes in an enclosure or OEM type packaging. Custom package options are also available.

DIT-5200 Enclosure

The DIT-5200 enclosure is a die cast aluminum box with MCX style sensor connections. The I/O is on a 9 pin mini-D connector.

DIT-5200 OEM

The DIT-5200 OEM version comes either with MCX or integral sensor connections. Integral sensor connections are recommended for small ranges. The I/O connection is on a 10 pin header. An 18" power cable with the 10 pin header connection on one end and a 9 pin mini D connection is provided with the unit. Some OEM versions have an integral I/O cable. The assembly is normally potted for protection of the circuit components.

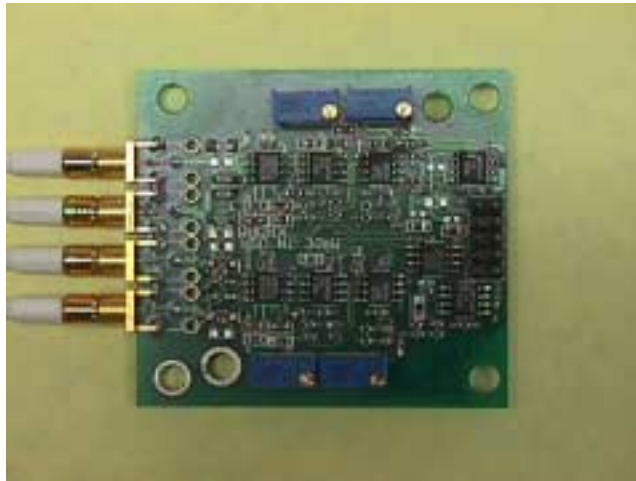

Setting up the DIT-5200

What's Included

- DIT-5200 Electronics
- 2 or 4 sensors (15N or 20N)
- 18" I/O Cable
- DIT-5200 User Manual

Cautions and Safeguards

The sensor faces may be damaged if allowed to strike the target or other hard surface. Please keep the protective plastic caps in place until you are ready to install the sensors.

The maximum input voltage to the DIT-5200 is +/-15.5V, exceeding this input voltage will cause damage to the DIT-5200.

Caution: The ground pin wiring is the red wire because the color code scheme was in order of the spectrum. Be careful not to connect the ground pin to the supply voltage or you will damage the unit.

Pin out and Connector Assignments

I/O Connections

Caution: The ground pin wiring is the red wire because the color code scheme was in order of the spectrum. Be careful not to connect the ground pin to the supply voltage or you will damage the unit.

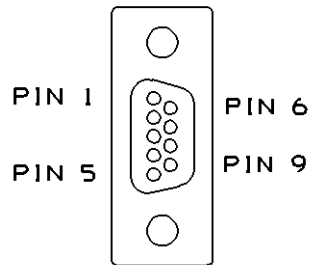

ITT Cannon Connector MDM-9SL2P

Pin	Color	Function
1	Black	+15V @ 40 mA (typical).
2	Brown	-15V @ 40 mA (typical)
3	Red	Power Supply Common
4	Orange	+X Output
5	Yellow	-X (Gnd)
6	Green	+Y Output
7	Blue	-Y(Gnd)
8	Violet	KT-1 (optional)
9	Gray	KT-2 (optional)

I/O Connector Pinout

Note: On single channel systems only the X channel is used.

Sensor Connections

The sensor connections are the same for both the enclosure style and the OEM DIT-5200. On the OEM DIT-5200 orient the box so the connector is on the right and the sensor connections are on the left.

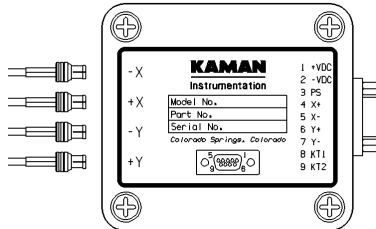

Function	Sensor Label
Axis 1 Positive Sensor	+X
Axis 1 Negative Sensor	-X
Axis 2 Positive Sensor	+Y
Axis 2 Negative Sensor	-Y

Sensor Connections

Note: The output on the channel will go more positive with movement toward the positive (+) sensor. The output on the channel will go more negative with movement toward the negative (-) sensor.

Note: On single channel systems only the X channel is used.

Note: The system is set up with the sensors as marked. Swapping sensors may result in degraded performance without factory recalibration.

Applications Information

For differential measurement applications, the two electronically matched sensors are positioned on opposite sides or ends of the target. The sensor to target relationship is such that as the target moves away from one sensor, it moves toward the other an equal amount.

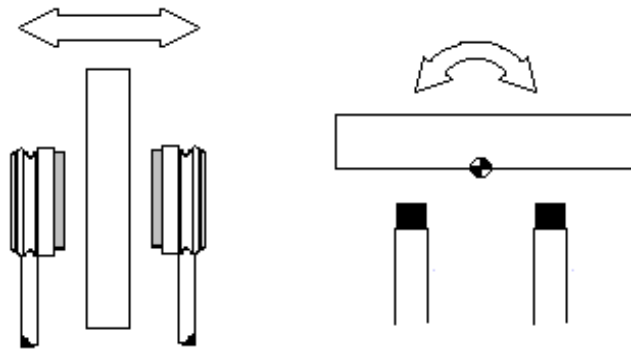

Sensor Target Relationship

A standard systems comes with two measurement axes (four sensors; two per axis) and can therefore be fixtured a number of ways to provided precise x-y alignment. The figure below illustrates target configuration for x-y alignment of an image stabilization mirror for an electro-optical application.

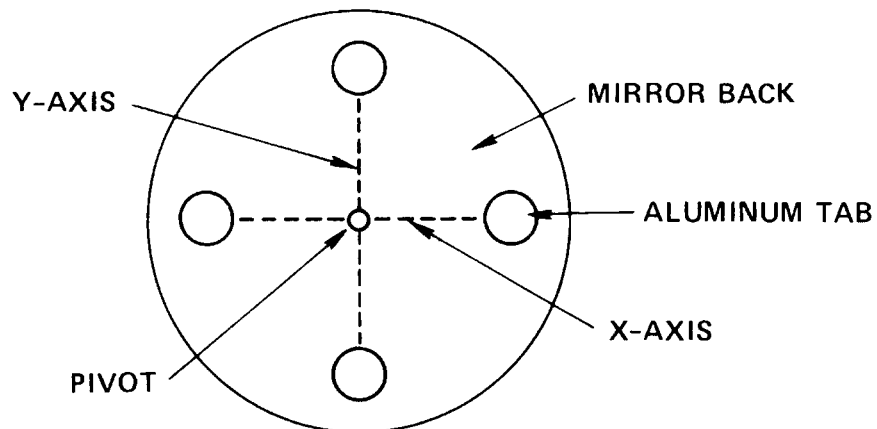

Fixturing

The user provides fixturing for the DIT-5200 electronics and sensors. The following information establishes fixturing requirements for optimum system performance. Both the sensor *and* target fixturing must be structurally sound and repeatable

Factors that may degrade performance are:

Unequal Loading:

This refers to an unequal amount of conductive material within the field of one sensor as opposed to the other sensor in the pair (the sensor's field is approximately three times its diameter). Unequal loading causes asymmetrical output from the sensors which induces non-linearity in the system output. Ideally, no conductive material other than the target should be in the sensor's field. Some loading may be acceptable if it is equal and the sensors are calibrated in place. Even then, sensor loading may cause non-linearity. If unable to calibrate, then loading is too great.

Unequal Displacement

For targets using pivot point mount, the system should "see" equal displacement: i.e., the pivot point of the target is perfectly centered between the sensors. If the pivot point is a fraction of a centimeter off, it can introduce non-linearity into the system.

Additional Pivot Point Requirements

- The pivot point must be on a common line between the centerline of a pair of sensors.
- The axis of tilt must be a perpendicular bisector of a line between the centerlines of a sensor pair.
- The pivot point must be positioned on the target so as not to introduce a translation error. This error, a function of angle, is caused by slight changes in the effective null gap as the target moves about the pivot. This results in non-linearity.
- The pivot point must not move or change with time.

Sensor Mounting and Installation

The sensors must be securely clamped. A collet type fixture is the best. It is best to clamp the fixture as close to the sensor face as possible (without causing additional loading on the sensor) – this is to minimize expansion differences between the two sensor housings. To insure that the fixturing does not load the sensor and cause performance errors you should have any metal parts approximately 3 sensor diameters away from the tip.

The target must not strike the sensor face. The sensor should have a null gap and measuring range specified on the calibration record. As an example a 15N sensor may have a null gap of 15 mils (0.015” / 0.381mm) and a range of +/-10 mils (+/-0.010” / +/- 0.254 mm). The difference between the null gap and measuring range is the offset distance for the sensors. In this example the offset would be $15-10=5$ mils for an offset. The offset is the closest distance the sensor gets to the target during normal operation. This offset is necessary both to optimize performance and to keep the target from contacting and possibly damaging the coils in the sensor face.

Install the sensors so that only the target interacts with the sensor’s field. No conductive material other than the target should be present within the sensor’s field. Because the sensor field radiates in all directions, excessive back loading can also be a problem.

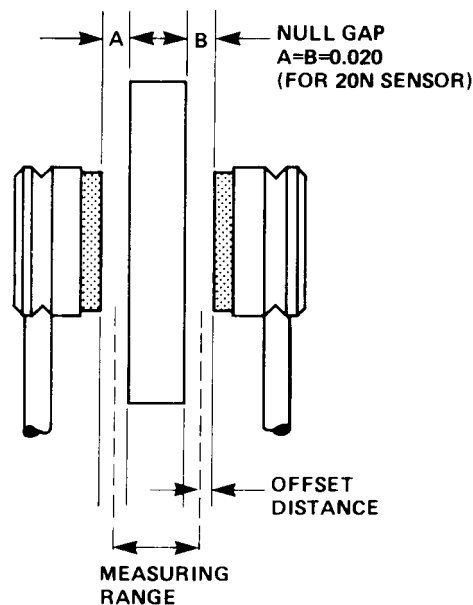

Electrical Nulling Procedure

Note: Although both sensors may be positioned mechanically, this can cause a cumulative error. By electrically positioning the second sensor using the system output, the error is minimized.

The sensor coil is mounted at the face of both sensors. For purposes of mechanical nulling, measure distance from the sensor face. (Use care not to damage the sensor coil)

1. Sensor position relative to the target is critical. Make sure the target is in the null position. Install the first sensor of a pair (start with X-) in the application fixture. Using a dimensional standard, precisely locate the sensor at the null gap. Secure the sensor and recheck its position.
2. Now install the second sensor of the pair (X+) in the fixture and position it to within a few mils (10's of microns) of the required null gap. Connect the Power/Signal line and apply power to the system. (Connecting power incorrectly may cause damage to the DIT-5200!!!). Use the output from the system as a guide in the final positioning of this sensor (electrical nulling). Slowly move the second sensor toward or away from the target as necessary until the system output reads 0VDC (typically +/-10mV). Secure the sensor and recheck that the output is 0VDC. This output means the sensor is positioned correctly.
3. Repeat steps 1 and 2 for sensor Y- and Y+.

The system is now ready for use.

Optimizing Performance

There are several things to be aware of when using the DIT-5200 in order to optimize the performance of the system.

- Insure that there are no 'incidental targets' – i.e. targets that the sensor may see that are not to be measured.
- Insure that the sensor is not tilted with respect to the target as this will cause additional non-linearity.
- Make sure that the system is set up with the proper null gap – electrical nulling of the second sensor in a pair is best.
- Insure you are using the specified calibration material (aluminum is the standard).
- Make certain that you are using stable fixturing and mounting of the sensors.
- Ensure the target is 3 sensor diameters in size and is thick enough to prevent penetration of the magnetic field. (see the section on **Targets**)
- The system will perform the best if both sensors are in a similar thermal environment – avoid temperature differentials between the sensor pairs.

Targets (Material, Thickness, Size)

Target Material

Iron, nickel, and many of their alloys (magnetic targets) are not acceptable for use with the DIT-5200.

Aluminum is the preferred target material for the DIT-5200. Magnetic targets such as iron, nickel, and many of their alloys should not be used with the DIT-5200. Aluminum targets may be mounted on materials with more stable temperature characteristics such as Invar or other substrates as long as the target thickness guidelines are observed. . Invar is an excellent target substrate as it has a very low expansion coefficient with temperature. The figure below shows aluminum tabs (which give optimal performance from the DIT-5200) mounted on and Invar fixture. Invar, however, is not acceptable for use as a target with the DIT-5200.

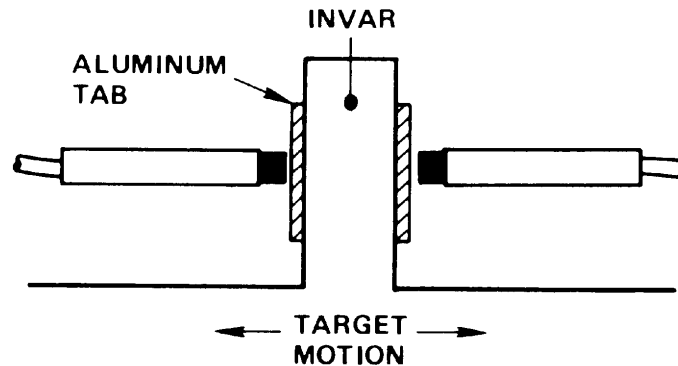

If you purchased as system for use with a target material other than aluminum, it has been pre-calibrated (with pre-selected component values) at the factory using that target material. Changing the target material may require re-calibration or cause the DIT-5200 to malfunction.

The effect of target material is due to the resistivity and mainly affects the sensitivity of the system. Expect about twice as much noise and drift on a system set up for a stainless steel target as compared to one set up for aluminum.

Target Thickness

The RF field produced by the sensor is maximum on the target surface, but it also penetrates below the surface. The depth of penetration depends on the target material used. For example, the RF field will penetrate aluminum 0.022". To avoid variations caused by temperature changes of the target, use the recommended minimum target thickness in the table below:

Material	Thickness, mils (mm)
Silver and Copper	22 (0.558)
Gold and Aluminum	22 (0.558)
Beryllium	25 (0.635)
Magnesium, Brass, Bronze, Lead	58 (1.473)
300 Series Stainless Steel	110 (2.794)
Inconel	110 (2.794)

Note: *In applications where the sensors oppose each other with the target between them, the minimum thickness should be at least double those listed above to prevent sensor interaction.*

Target Size

The minimum target size must be 1 ½ to 2 times the sensor diameter. It is preferred that the target size be 3 times the sensor diameter for optimum performance.

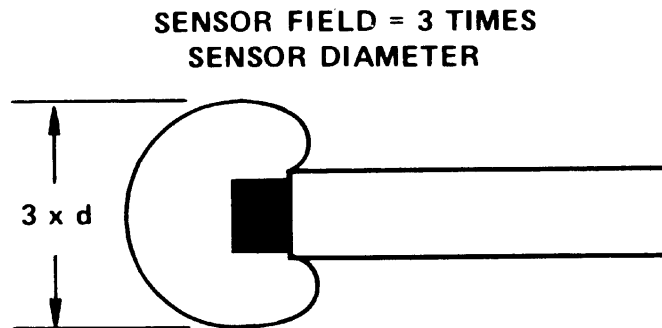

Calibration

The DIT-5200 systems are shipped from the factory pre-calibrated for a user specified measuring range, sensitivity, and target material. They do not normally require calibration or re-calibration; however, some applications may require this option. The pot locations for the OEM and enclosure version are the same relative to the sensor and I/O connector positions.

Note: *If there is only one set of potentiometers then the system must be zeroed by first adjusting one sensor to the null gap and adjusting the opposing sensor for a zero volt output.*

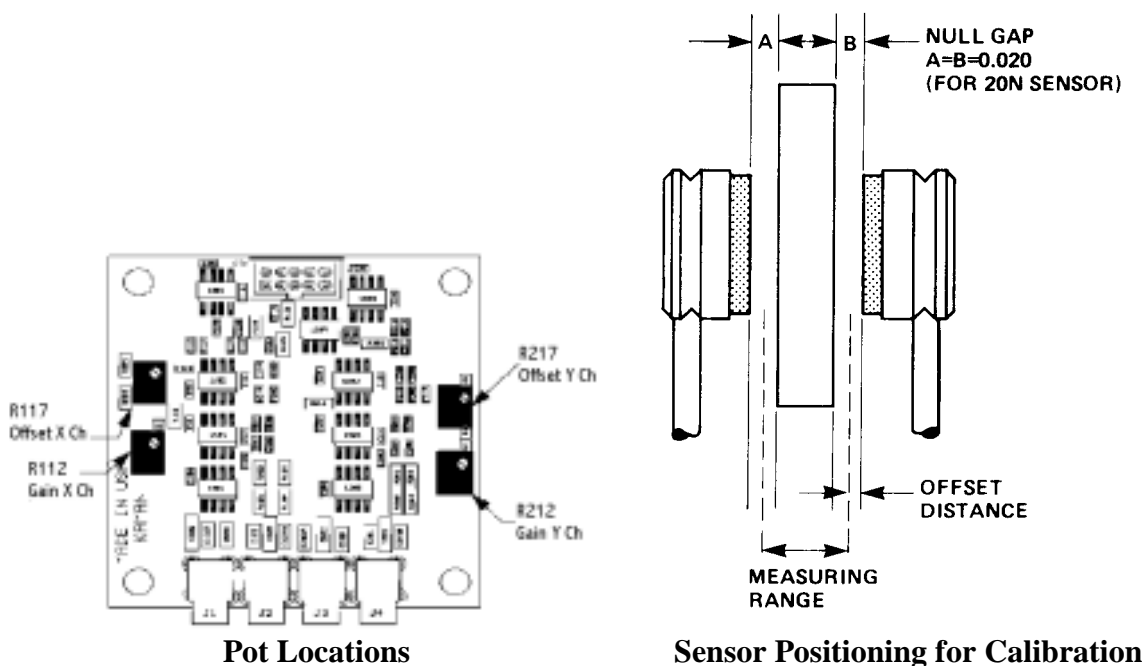

1. Position the target at Null
2. Adjust the zero control for the measuring channel being calibrated to $0 \pm 0.001V$ (unless otherwise specified). (See above note if there is no zero control)
3. Position the target at $-FS$ (-full scale)
4. Adjust the gain control for the measuring channel being calibrated to the full scale voltage $\pm 0.005mV$ (unless otherwise specified)
5. Position the target at Null
6. Adjust the zero control for the measuring channel being calibrated to $0 \pm 0.001V$ (unless otherwise specified). (See above note if there is no zero control)
7. Position the target at $-FS$ (-full scale)
8. Adjust the gain control for the measuring channel being calibrated to the full scale voltage $\pm 0.005mV$ (unless otherwise specified)
9. Repeat steps 1-9 as necessary

Technology

The DIT-5200 uses advanced inductive measurement technology to detect the aligned or centered position of a conductive target. For differential measurement applications, two precisely matched sensors per channel are positioned on opposite sides or ends of a target. In this sensor-to-target relationship, as the target moves away from one sensor, the target moves toward the other sensor an equal amount. Output is differential and bipolar. The electrically matched sensors on opposing legs of the same bridge provide exceptional thermal stability.

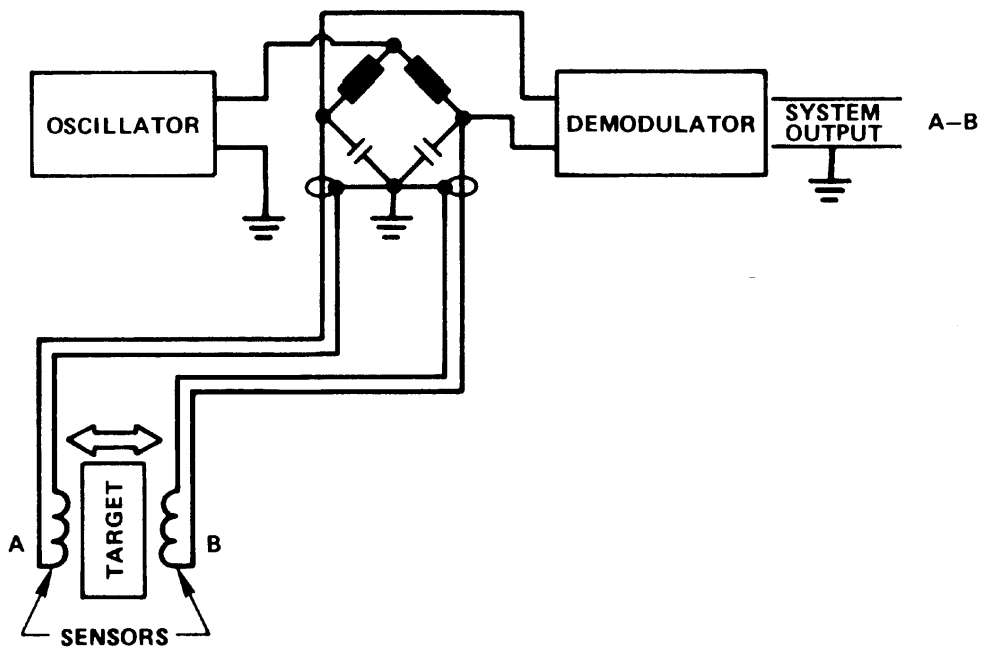

System Performance and Specifications

General Specifications and Typical Performance

Parameter	Value	Units	Comments
Target Material	Aluminum		most non-magnetic materials will be considered
Null Gap	See Table		
Range	See Table		
Output Voltage	+/-10	Volts	Typical
Non-Linearity	<0.5	%FSO	Typical (See Table)
Resolution at Null (p-p at 1kHz BW)	<0.004	%FSO	Typical (See Table for Min)
Resolution at FSO (p-p @ 1kHz BW)	<0.015	%FSO	Typical (See Table for Min)
TempCo at Null	<0.005	%FSO/°C	Typical
TempCo at FSO	<0.02	%FSO/°C	Typical
Power Dissipation at 15N Sensor Head	< 0.5	mW/sensor	Typical
Power Dissipation at 20N Sensor Head	< 2	mW/sensor	Typical
Power Dissipation (Electronics)	<1.35	Watts	
Frequency Response	0-20	kHz	
Input Voltage	+/-15	Volts	
Output Impedance	<1	Ohm	
Weight	<8	oz	Enclosure Version (Typ)

Operating Temperature

Electronics: +32to +140°F (0C to +60°C)

Sensors: -62°F to +220°F (-52°C to +105°C)

Cryogenic 20N Sensor: +4°K to +220°F (+105°C)

Storage Temperature Range

Electronics: -26°F to +180°F (-32°C to +82°C)

Sensors: -62°F to +220°F (-52°C to +105°C)

Cryogenic 20N Sensor: +4°K to +220°F (+105°C)

Sensor/Range Specific Performance

Range, +/-mil	Range Mm	Null, mil	Null, mm	15N	20N	Typical Non-Linearity, %FR	Max. Non-Linearity, %FR	Typical Sensor TempCO, %FR/°C	Equivalent RMS Input Noise, %FR/√Hz at FR	Equivalent RMS Input Noise, %FR/√Hz at Null
1	0.03	7	0.18	x		0.10%	0.20%	0.05%	0.00024%	0.00007%
5	0.13	10	0.25	x		0.10%	0.20%	0.02%	0.00014%	0.00004%
5	0.13	15	0.38		x	0.10%	0.20%	0.02%	0.00024%	0.00008%
10	0.25	15	0.38	x		0.15%	0.30%	0.02%	0.00007%	0.00002%
10	0.25	20	0.51		x	0.10%	0.20%	0.02%	0.00012%	0.00004%
20	0.51	25	0.64	x		0.25%	0.50%	0.03%	0.00004%	0.00002%
20	0.51	40	1.02		x	0.15%	0.30%	0.02%	0.00007%	0.00002%
35	0.89	40	1.02	x		0.50%	1.00%	0.03%	0.00004%	0.00002%
50	1.27	60	1.52		x	0.25%	0.50%	0.03%	0.00004%	0.00002%
75	1.91	85	2.16		x	0.50%	1.00%	0.03%	0.00002%	0.00002%

Note: Full Range (FR) is considered as twice the +/-Range

Calculating Effective Resolution

To calculate the effective resolution, take the Equivalent RMS Input Noise and multiply it by the square root of the measurement bandwidth. Peak-to-peak noise is normally 6.6 times higher than the RMS noise assuming gaussian (randomly distributed) noise.

For Example, to calculate the worst case noise of a 15N system with a +/-500 micrometer range at a 20kHz bandwidth:

Step 1) Calculate the full range of the system:

$$\text{FR (Full Range)} = 2 \times 500 \text{ micrometer} = 1000 \text{ micrometers}$$

Step 2) Calculate the Equivalent RMS Input Noise in measurement units by multiplying by the Full Range (*don't forget to divide by 100 to take into account the percent*).

$$\text{Resolution at Full Scale is } 0.00004\% \text{FR}/\sqrt{\text{Hz}} \times 1000 \text{ micrometers} / 100\% = 0.0004 \text{ micrometers}/\sqrt{\text{Hz}}$$

Step 3) Multiply by the square root of the measurement bandwidth to calculate the effective resolution.

$$\text{Effective RMS Resolution at 20kHz} = 0.00004\% \text{FR}/\sqrt{\text{Hz}} \times 1000 \text{ micrometers} \times \sqrt{20 \text{ kHz}} = 0.056 \text{ micrometers}$$

Step 4) To approximate the peak-to-peak resolution multiply by 6.6

Effective peak-to-peak resolution at 20 kHz = $0.056 \times 6.6 = 0.37$ micrometers

Note: *The output filtering on the DIT-5200 is set to 20kHz -- external filtering is assumed when calculating resolutions at other bandwidths.*

Troubleshooting

Insufficient Gain

If attempting to recalibrate for a specific sensitivity, measuring range, or for a target different from factory calibration specifications, there may be insufficient gain control to do this. You may need to decrease the desired output in order to calibrate the system.

Another cause for insufficient gain could be excessive loading of the sensors by conductive material (other than the target) within the field of the sensors. The sensor's field is approximately three times its diameter.

Unable to Zero

The DIT-5200 is an exceptionally stable measuring system. Long term drift is less than 2 microinches per month. If the unit does not work, this would most likely be discovered during the functional test. If you are unable to calibrate your system in no more than two iterations, the problem is most likely poor mechanical repeatability in the fixturing or actuating mechanisms. To determine this:

1. Do not make any adjustments to the calibration controls. (Record how much time the next step takes).
2. Do at least 12 to 15 iterations of moving the target from null to full range and back to null. Record the output at null each time. If successive readings of the output at null consistently vary with no clear trend (drift) in one direction or the other, the problem is mechanical repeatability.
3. Stabilize the target at null and record the output. Leave the target at null for the same length of time it took to accomplish step two and monitor the output.
4. If the output remains constant, this confirms the problem is mechanical repeatability.

If the output drifts, the problem could be drift in the fixturing, drift in the target positioning servos, or drift in the DIT-5200.

If you can positively eliminate all other variables as the source of the problem, consult Kaman Instrumentation.

Poor Non-Linearity

Poor non-linearity is typically the result of additional loading on the sensor or the sensor head being slightly tilted.

DIT-5200 OEM Outline Drawing and Dimensions

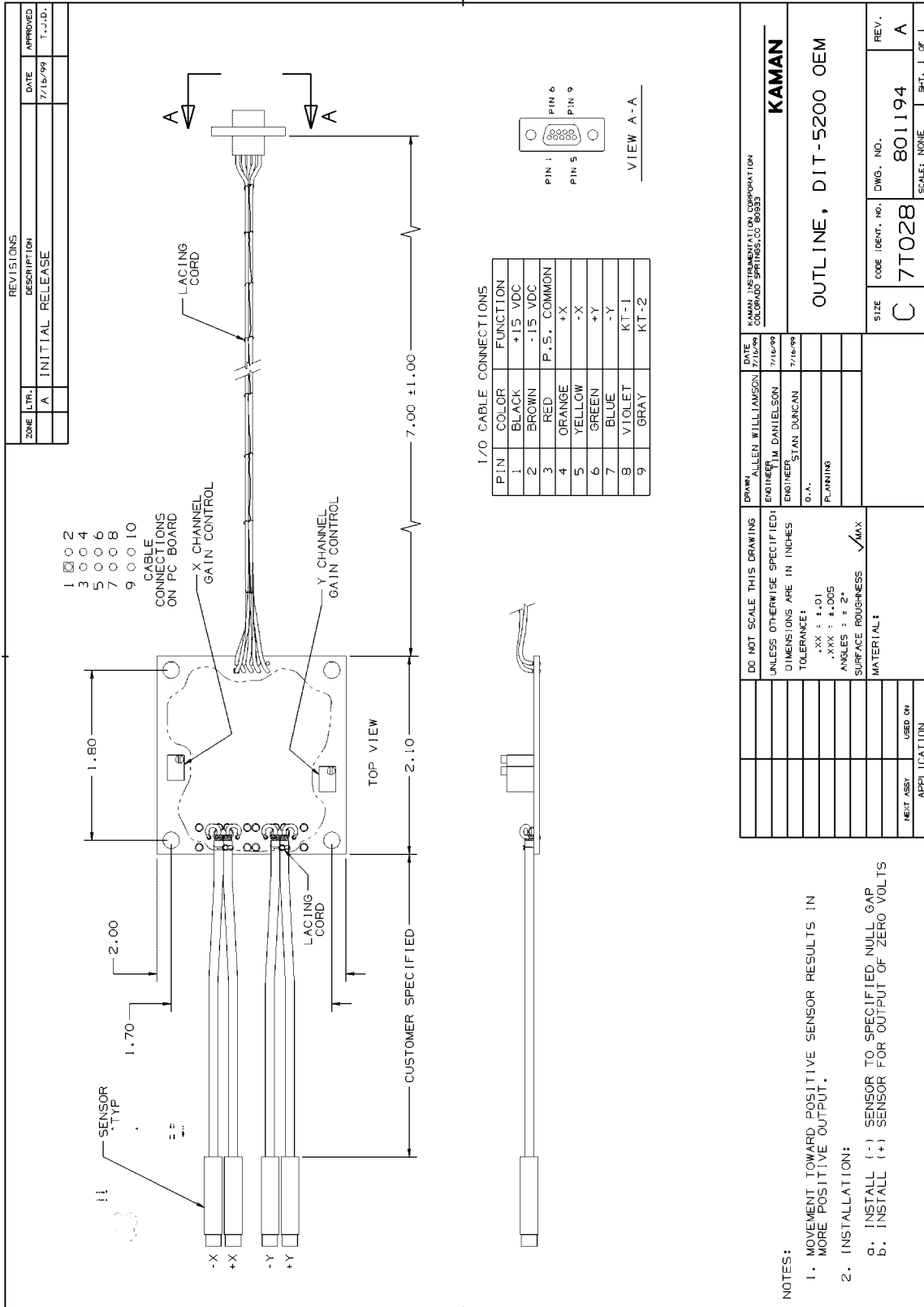

DIT-5200 Sensor Dimensions

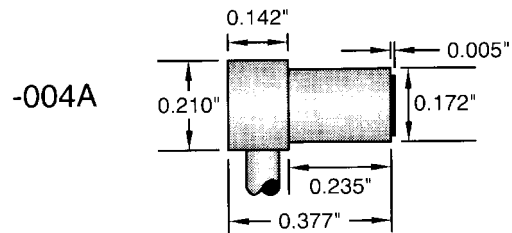
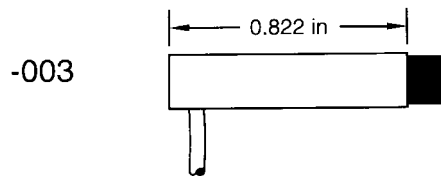
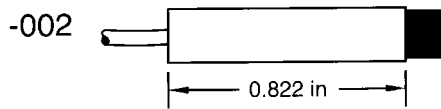
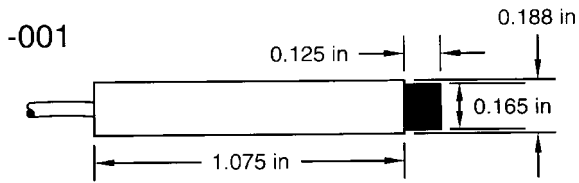

-004B total length = 0.506"

15N Sensors

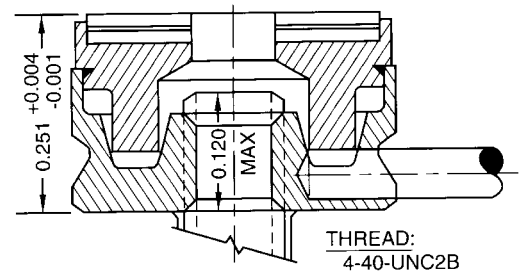
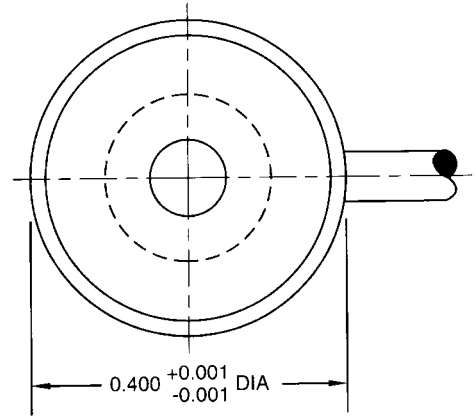

3X ACTUAL SIZE

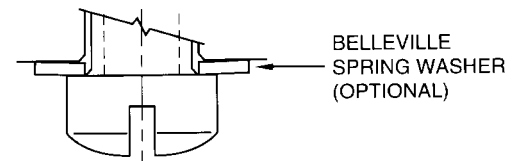

20N Sensor

Terminology

Null Gap

The point at which a target is equidistant from each sensor of a differential pair. The system output at null = 0VDC. The actual gap is measured from the sensor face to the corresponding target face and includes a required offset (null gap = offset plus maximum measuring range).

Offset

The minimum distance between the sensor face and the target. Offset is necessary to both prevent the target from striking the sensor face and to optimize performance (offset = null gap minus max range).

Measuring Range

The full range of target motion over which the various specifications such as resolution, linearity, and sensitivity can be met. The differential sensor arrangement yields a bipolar output and measuring range is expressed as + and – value either side of the null position (measuring range = null gap minus the offset).

Sensitivity (scale/gage factor)

Output voltage per unit of displacement. Usually expressed as millivolts per mil (0.001”) or per millimeter.

Linearity (or non-linearity)

The maximum deviation of any point of a calibrated system’s output from a best fit straight line. Expressed in actual units, e.g., microinches or as a percentage of the full range (the full scale output times 2).

Equivalent RMS Input Noise

A figure of merit used to quantify the noise contributed by a system component. It incorporates into a single value, several factors that influence a noise specification such as signal-to-noise ratio, noise floor, and system bandwidth. Given a measuring systems sensitivity/scale factor and the level of “white” noise in the system, Equivalent RMS Input Noise can be expressed using actual measurement units.

Effective Resolution

An application dependent value determined by multiplying the Equivalent RMS Input Noise specification by the square root of the measurement bandwidth.

Example: an application with a 100 Hz bandwidth using a DIT-5200 with an Equivalent RMS Input Noise level of $0.2\text{nm}/\sqrt{\text{Hz}}$ results in a system with an effective resolution of $0.2\text{nm}/\sqrt{\text{Hz}} \times \sqrt{100 \text{ Hz}}$ or 2nm.

Kaman Instrumentation Products Standard Limited Warranty

Products of Kaman Instrumentation are warranted to be free from defects in materials and workmanship when installed and operated in accord with instructions outlined in the instruction manual.

Kaman Instrumentation's obligation under this warranty shall be limited to repair or replacement (at the discretion of Kaman Instrumentation) of the defective goods returned to Kaman's plant within one (1) year from date of shipment. Extreme environment sensors are limited to the maximum operating temperature as specified within the most current Kaman Measuring Systems Extreme Environment Systems data sheets.

This warranty is valid except when the products have been subject to misuse, accident, negligent damage in transit or handling, or operation outside the conditions prescribed in the data sheet or instruction manual. This will be determined by Kaman Instrumentation personnel.

In no event shall Kaman be liable for incidental or consequential damages, including commercial loss, resulting from any article sold under this Agreement.

In the event Buyer fails to limit to Kaman's warranty set forth above, any express or implied warranty Buyer may make with respect to any product of which any article sold thereunder is a component, Buyer shall indemnify and hold Kaman harmless from any and all liability, costs and expenses to which Kaman may be subjected as a result of Buyer's failure to so limit its express or implied warranties.

THIS WARRANTY IS EXCLUSIVE AND IS MADE IN LIEU OF ALL OTHER WARRANTIES; AND THOSE IMPLIED WARRANTIES, INCLUDING SPECIFICALLY THE WARRANTIES OR MERCHANTABILITY AND FITNESS FOR A PARTICULAR PURPOSE ARE HEREBY EXPRESSLY LIMITED TO ONE (1) YEAR DURATION.

NO MODIFICATION OR ALTERATION OF THE FOREGOING WARRANTY AND LIMITATION OR REMEDIES PROVISIONS SHALL BE VALID OR ENFORCEABLE UNLESS SET FORTH IN A WRITTEN AGREEMENT SIGNED BY KAMAN AND THE BUYER.

Kaman Instrumentation Warranty No. 7A

Customer Service Information

Should you have any questions regarding this product, please contact an applications engineer at **Kaman Instrumentation Operations** 719-635-6979 or fax 719-634-8093. You may also contact us through our web site at: www.kamaninstrumentation.com.

Service Information

In the event of a malfunction, please call for return authorization:

Customer Service/Repair **Kaman Instrumentation Operations:**

860-632-4442